

Criterion®

User's Manual

Refrigerator-Freezer

MODEL: CFDR225M3S

Before using your product, please read this manual carefully and keep it for future reference.

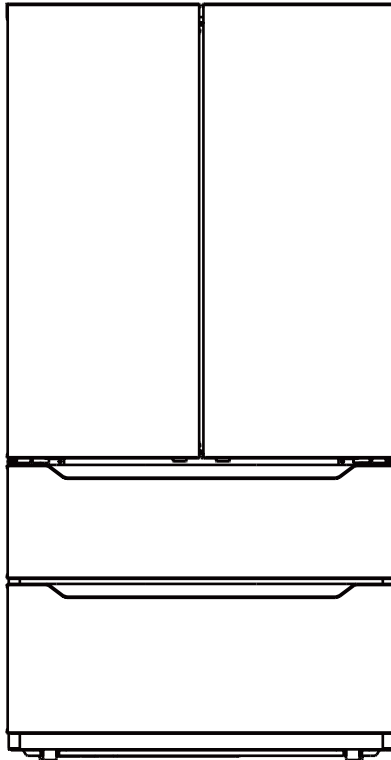

CONTENTS

1.SAFETY INFORMATION	1
2.PROPER USE OF REFRIGERATOR	8
2.1 Placement	8
2.2 Energy Saving Tips.....	9
2.3 Changing The Light	9
2.4 Start To Use	9
2.5 Names Of Components	10
2.6 Functions	12
2.7 Leveling Feet	14
2.8 Leveling Door.....	14
3.MAINTENANCE OF REFRIGERATOR	15
3.1 Overall Cleaning	15
3.2 Defrosting	16
3.3 Out Of Operation.....	16
3.4 Cleaning Of Door Tray.....	16
3.5 Cleaning Of Shelf	16
3.6 Installing The Water Line.....	17
3.7 Cleaning Of Freezer Lower Drawer	18
4.TROUBLE SHOOTING	19

1. SAFETY INFORMATION

YOUR SAFETY AND THE SAFETY OF OTHERS ARE VERY IMPORTANT

To prevent injury to the user or other people and property damage, the instructions shown here must be followed. Incorrect operation due to ignoring of instructions may cause harm or damage, including death.

The level of risk is shown by the following indications.



This is a prohibition symbol.

Any in compliance with instructions marked with this symbol may result in damage to the product or endanger the personal safety of the user.



This is a warning symbol.

It is required to operate in strict observance of instructions marked with this symbol; or otherwise damage to the product or personal injury may be caused.



This is a cautioning symbol.

Instructions marked with this symbol require special caution. Insufficient caution may result in slight or moderate injury, or damage to the product.

IMPORTANT SAFETY INSTRUCTIONS



Risk Of Fire / Flammable Materials



WARNING

- This appliance is intended to be used in household and similar applications such as staff kitchen areas in shops, offices and other working environments; farm houses and by clients in hotels, motels and other residential type environments; bed and breakfast type environments; catering and similar non-retail applications.
- This appliance is not intended for use by persons (including children) with reduced physical, sensory or mental capabilities, or lack of experience and knowledge, unless they have been given supervision or instruction concerning use of the appliance by a person responsible for their safety.

- Children should be supervised to ensure that they do not play with the appliance.
- If the supply cord is damaged, it must be replaced by the manufacturer, its service agent or similarly qualified persons in order to avoid a hazard.
- Do not store explosive substances such as aerosol cans with a flammable propellant in this appliance.
- The appliance has to be unplugged after use and before carrying out user maintenance on the appliance.
- **WARNING:** Keep ventilation openings, in the appliance enclosure or in the built-in structure, clear of obstruction.
- **WARNING:** Do not use mechanical devices or other means to accelerate the defrosting process, other than those recommended by the manufacturer.
- **WARNING:** Do not damage the refrigerant circuit.
- **WARNING:** Do not use electrical appliances inside the food storage compartments of the appliance, unless they are of the type recommended by the manufacturer.
- **WARNING:** Please abandon the refrigerator according to local regulators for its use of flammable blowing gas and refrigerant.
- **WARNING:** When positioning the appliance, ensure the supply cord is not trapped or damaged.
- **WARNING:** Do not locate multiple portable socket-outlets or portable power supplies at the rear of the appliance.
- Do not use extension cords or ungrounded two prong adapters.
- **WARNING:** Connect to potable water supply only. (suitable for ice cube maker)
- **WARNING:** To avoid a hazard due to instability of the appliance, it must be fixed in accordance with the instructions.



DANGER

- The refrigerator must be disconnected from the source of electrical supply before attempting the installation of accessory.
- Refrigerant and cyclopentane foaming material used for the appliance are flammable. Therefore, when the appliance is scrapped, it shall be kept away from any fire source and be recovered by a special recovering company with corresponding qualification other than be disposed by combustion, so as to prevent damage to the environment or any other harm.
- TO Prevent A Child From Being Entrapped, Keep Out Of Reach Of Children And Not In The Vicinity Of Freezer (Or Refrigerator). (Suitable for products with locks)



WARNING

- Risk of child entrapment. Before you throw away your old refrigerator or freezer:
 - Take off the doors.
 - Leave the shelves in place so that children may not easily climb inside.

SAVE THESE INSTRUCTIONS

THIS APPLIANCE IS FOR HOUSEHOLD USE ONLY

State of California Proposition 65 Warnings:

 **WARNING:** Cancer and Reproductive Harm
-www.P65Warnings.ca.gov.

PROPER DISPOSAL

WARNING

Suffocation Hazard

Before you throw away your old freezer or refrigerator:

- Remove the door or lid so that children cannot hide or get trapped inside your old appliance.
- Leave any shelves in place so that children may not easily climb inside.
- Failure to follow these instructions can result in death or brain damage.

IMPORTANT:

Flammable gas and refrigerant used. It is the consumer's responsibility to comply with Federal and Local regulations when disposing of this product. Refrigerants must be evacuated by a licensed, EPA certified refrigerant technician in accordance with established procedures.

ELECTRICITY RELATED WARNINGS

- Do not pull the power cord when pulling the power plug of the refrigerator. Please firmly grasp the plug and pull out from the socket.
- To ensure safe use, do not damage the power cord or use the power cord when it is damaged or worn.
- Please use a dedicated power socket; the power socket shall not be shared with other electrical appliances.

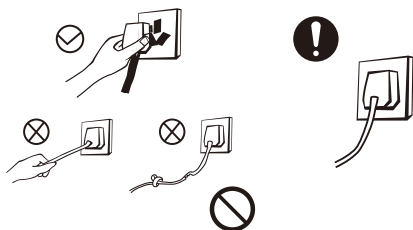

- The power cord should be firmly contacted with the socket, otherwise fire may be caused.
- Please ensure that the grounding electrode of the power socket is equipped with a reliable grounding line .
- Please turn off the valve of leaking gas and then open doors and windows in case of leakage of gas and other flammable substances. Do not unplug the refrigerator and other electrical appliances considering that spark may cause a fire.

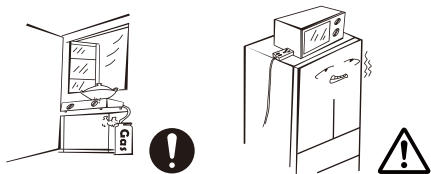

- Do not use electrical appliances on top of the appliance, unless they are of the type recommended by the manufacturer.

WARNINGS RELATED TO PLACING ITEMS

- Do not place flammable, explosive, volatile and highly corrosive items in the refrigerator to prevent damages to the product or fire accidents.
- Do not place flammable items near the refrigerator to avoid fires.

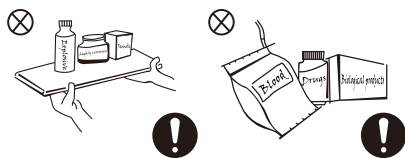

- This product is a household refrigerator and is only suitable for the storage of foods. According to national standards, a household refrigerator shall not be used for other purposes, such as storage of blood, drugs or biological products.
- Do not store beer, beverages or other fluids contained in bottles or enclosed containers in the freezing chamber of the refrigerator, otherwise the bottles or enclosed containers may crack due to freezing and cause damages.



WARNINGS FOR USE

- Do not arbitrarily disassemble or reconstruct the refrigerator, nor damage the refrigerant circuit; maintenance of the appliance must be conducted by a specialist.
- A damaged power cord must be replaced by the manufacturer, its maintenance department or related professionals in order to avoid danger.
- Do not allow children to enter or climb inside the refrigerator to prevent that children are sealed in the refrigerator or injured by the falling refrigerator.
- Do not spray or wash the refrigerator; do not place the refrigerator in moist places easy to be splashed with water so as not to affect the electrical insulation properties of the refrigerator.

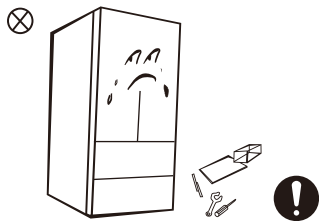

- The gaps between refrigerator doors and between doors and refrigerator body are small, do not place your hands in these areas to prevent squeezing your fingers. Please be gentle when opening the refrigerator door to avoid articles falling out.
- Do not pick up food or containers with wet hands in the freezing chamber when the refrigerator is running, especially metal containers in order to avoid frostbite.

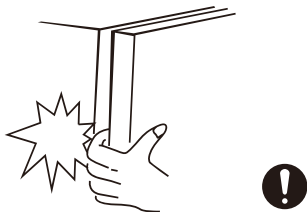

- Do not place heavy objects on top of the refrigerator considering that objects may fall when opening the door, and accidental injuries might be caused.
- Please pull out the plug in case of power failure or cleaning. Do not connect the refrigerator to power supply within five minutes to prevent damages to the compressor due to successive starts.

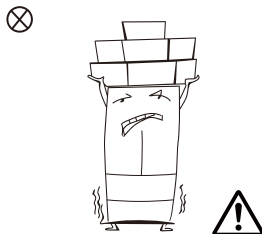

ENERGY WARNINGS

- 1.** Refrigerating appliances might not operate consistently (possibility of defrosting of contents or temperature becoming too warm in the frozen food compartment) when set for an extended period of time below the cold end of the temperature range for which the refrigerating appliance is designed.
- 2.** Effervescent drinks should not be stored in food freezer compartments or cabinets or in low-temperature compartments or cabinets because some products such as water ice should not be consumed too cold;
- 3.** Do not exceed the storage time(s) recommended by the food manufacturers for any kind of food and particularly for commercially quick-frozen food in food-freezer and frozen-food storage compartments or cabinets
- 4.** Prevent an undue rise in temperature of frozen food while defrosting the refrigerating appliance, such as wrapping the frozen food in several layers of newspaper.
- 5.** A rise in temperature of frozen food during manual defrosting, maintenance or cleaning can shorten the storage life

DISPOSAL



Refrigerant and cyclopentane foaming material used for the refrigerator are flammable. Therefore, when the refrigerator is scrapped, it shall be kept away from any fire source and be recovered by a special recovering company with corresponding qualification other than be disposed by combustion, so as to prevent damage to the environment or any other harm.



When the refrigerator is scrapped, disassemble the doors, and remove gasket of door and shelves; put the doors and shelves in a proper place, so as to prevent trapping of any child.

Correct Disposal of this product:



This marking indicates that this product should not be disposed with other household waste. To prevent possible harm to the environment or human health from uncontrolled waste disposal, recycle it responsibly to promote the sustainable reuse of material resources. To return your used device, please use the return and collection systems or contact the retailer where the product was purchased. They take this product in for environmental safe recycling.

2. PROPER USE OF REFRIGERATOR

2.1 PLACEMENT

- Before use, remove all packing materials, including bottom pads, foam pads and tapes inside of the refrigerator; tear off the protective film on the doors and the refrigerator body.

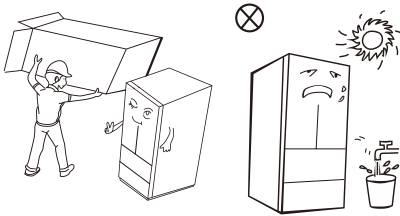

- Keep away from heat and avoid direct sunlight. Do not place the freezer in moist or wet places to prevent rust or reduction of the insulating effect.
- Do not spray or wash the refrigerator; do not put the refrigerator in moist places easy to be splashed with water so as not to affect the electrical insulation properties of the refrigerator.

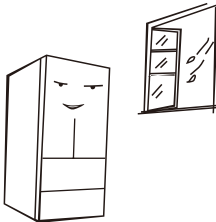

- The space on top of the refrigerator shall be greater than 10cm, and the refrigerator should be placed against a wall with a distance of more than 10cm to facilitate heat dissipation.

Spare enough space for convenient opening of the doors and drawers or statement by the distributor.

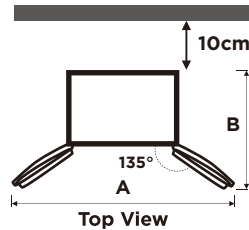
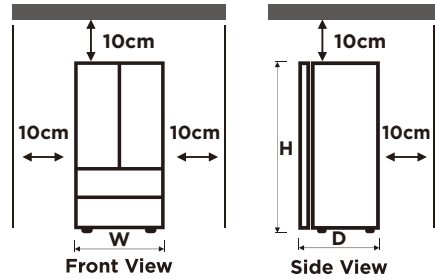

Width "w"	910
Depth "D" (without handle)	737
Height "H"	1775
A	1600
B	1047

(unit: mm)

The measurements in the above table may differ, depending on the measuring method.

NOTE

This refrigerator needs to be installed independently and cannot be used as a built-in. Otherwise, it will cause problems such as failure to install into the cabinet, the performance and life of the product are reduced. And the manufacturer does not provide basic product warranty.

2.2 ENERGY SAVING TIPS



- The appliance should be located in the coolest area of the room, away from heat producing appliances or heating ducts, and out of the direct sunlight.
- Let hot foods cool down to room temperature before placing it in the appliance. Overloading the appliance forces the compressor to run longer. Foods that freezes too slowly may lose quality, or spoil.
- Be sure to wrap foods properly, and wipe containers dry before placing them in the appliance. This cuts down on frost build-up inside the appliance.
- Appliance storage bins should not be lined with tin foil, wax paper, or paper toweling. Liners interfere with cold air circulation, making the appliance less efficient.
- Organize and label food to reduce door openings and extended searches. Remove as many items as needed at one time, and close the door as soon as possible

2.3 CHANGING THE LIGHT

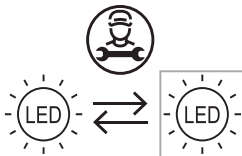
- Any replacement or maintenance of the LED lamps is intended to be made by the manufacturer, its service agent or similar qualified person.

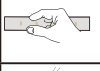
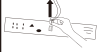

- Light source in this product is replaceable only by qualified engineers.

	1. Please take out the plug before removal.
	2. Remove the lampshade with a screwdriver.
	3. Take down the lamp panel.
	4. Remove the connection terminal.

2.4 START TO USE

- Before initial start, keep the refrigerator still for two hours before connecting it to power supply.
- Before placing any fresh or frozen foods, the refrigerator should have run for 2 - 3 hours, or for above 4 hours in summer when the ambient temperature is high.

NOTE

This product is not recommended for use with sockets or main switch with the A/GFCI function, otherwise it may cause false tripping.

1. it's not pose a safety risk when tripped.
2. If tripping persists, it is recommended to replace the sockets or main switch without A/GFCI function.

2.5 NAMES OF COMPONENTS

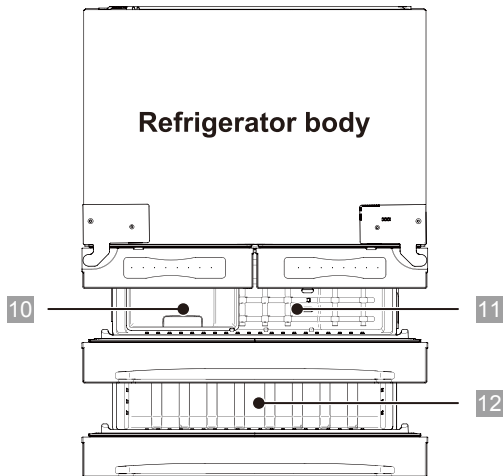
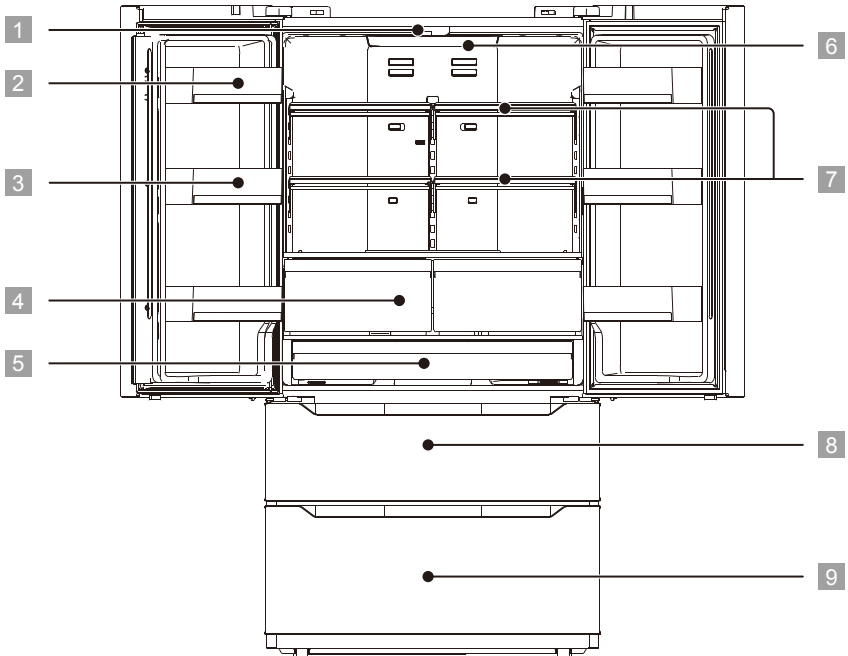

The picture above is only for reference. The actual configuration will depend on the physical product or statement by the distributor

1 LED lighting

3 Door tray

5 Big drawer

7 Shelf

9 Lower freezer drawer

11 Upper freezer drawer

2 Dairy Bin

4 Crisper drawer

6 Control and display panel

8 Upper freezer drawer

10 Ice storage bin

12 Lower freezer drawer

Refrigerating chamber

- The Refrigerating Chamber is suitable for storage of a variety of fruits, vegetables, beverages and other food consumed in the short term, suggested storage time 3days to 5days.
- Cooking foods shall not be put in the refrigerating chamber until cooled to room temperature.
- Foods are recommended to be sealed up before putting into the refrigerator.
- The glass shelves can be adjusted up or down for a reasonable amount of storage space and easy use.

Freezing chamber

- The low temperature freezing chamber may keep food fresh for a long time and it is mainly used to store frozen foods and making ice.
- The freezing chamber is suitable for storage of meat, fish, rice balls and other foods not to be consumed in short term.
- Chunks of meat are preferably to be divided into small pieces. Please be noted food shall be consumed within the shelf time.

NOTE

Storage of too much food during operation after the initial connection to power may adversely affect the freezing effect of the refrigerator. Foods stored shall not block the air outlet; or otherwise the freezing effect will also be adversely affected.

2.6 FUNCTIONS



1. Buttons

- ① Ice-making button
- ② Super cool button
- ③ Temperature adjusting button of refrigerator room
- ④ Temperature adjusting button of freezer room
- ⑤ Super freeze button
- ⑥ Lock / unlock button

2. Display

When electrify the refrigerator, the display screen will totally display for 3 seconds, meanwhile the starting up bell rings, then the display screen enters the normal display of operation. if power-on for first time, the default set temperature of the refrigerator room and the freezer room is 41°F / 0°F (4°C / -18°C).

It will display the set temperature of both refrigerator and freezer rooms when there is no fault.

Under normal circumstances, the display light will go out after 30 seconds in lock state, button operation on display panel would wake up the display screen; if the opening door action wakes up the display screen, the display light would go out immediately when the door is closed; when the "fault code visible" type of fault occurs, the display screen lights up, and will go out after 30 seconds.

- **Lock /unlock**

In the unlock state, press and hold the lock / unlock button for 3 seconds to enter the lock state , and the buzzer sound rings.

In the lock state, press and hold the lock button for 3 seconds to enter the unlock state and the buzzer sound rings.

It will enter the lock state if there is no opening door action or any buttons operation within 30 seconds.

The alarm sound can be stopped by pressing any one button in lock state, but all other button operations need to be performed in unlock state. If you operate in the lock state, an error beep will be given.

- **Refrigerator temperature setting**

Click the temperature adjusting button of refrigerator room to change the set temperature of refrigerator room, Each time click the button, the set temperature will drop 1°F (1°C). when the set temperature reaches the 34°F (2°C), click the button again, the set temperature will switch to 44°F (8°C). The temperature setting will take effect after the display panel is locked.

- **Freezer temperature setting**

Click the temperature adjusting button of freezer room to change the set temperature of freezer room, Each time click the button, the set temperature will drop 1°F (1°C). when the set temperature reaches the -7°F (-24°C), click the button again, the set temperature will switch to 7°F (-16°C). The temperature setting will take effect after the display panel is locked.

- **Mode setting**

Press the **SUPER COOL** button to start the super cool function. The refrigerator room is set at 34°F (2°C) automatically, and the **SUPER COOL** icon shines . When exit the super cool mode, the set temperature of refrigerator room will go back to the set temperature before super cool mode.

Press the **SUPER FRZ** button to start the super freeze function. The freezer room is set at -7°F (-24°C) automatically, and the **SUPER FRZ** icon shines. When exit the super freeze mode, the set temperature of freezer room will go back to the set temperature before super freeze mode.

Press the **ICE MAKER** button, the ice-making function could be switched between on/off. When the  icon is on, it indicates that the ice-making function is activated.

- **Error code**

When the following tips to appear on the display screen, it indicates a problem with the refrigerator. Although the refrigerator in the following fault case can still provide cool / freeze functions, but the user should contact maintenance personnel, ensure the normal use of refrigerator.

Fault Code	Fault Description
E1	Temperature sensor failure of refrigerator room
E2	Temperature sensor failure of freezer room
E5	Defrost sensor error of freezer room
E6	Communication error
E7	Ambient temperature sensor error
EH	Humidity sensor error
EO	Ice maker error

 **NOTE**

The quick-freezing function is designed to maintain the nutritional value of the food in the freezer. It can freeze the food in the shortest time. If a large amount of food is frozen at one time, it is recommended that the user turn on the quick-freezing function and put the food in. At this time, the freezing speed of the freezer compartment is increased, which can quickly freeze the food, effectively lock the nutrition of the food, and facilitate storage.

2.7 LEVELING FEET

- Schematic diagram of the levelling feet.

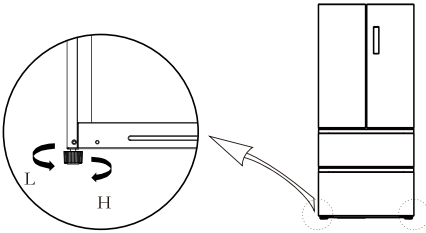

- Adjusting procedures:
 - a. Turn the feet clockwise to raise the refrigerator;
 - b. Turn the feet counterclockwise to lower the refrigerator;
 - c. Adjust the right and left feet based on the procedures above to a horizontal level.

The picture above is only for reference. The actual configuration will depend on the physical product or statement by the distributor

2.8 LEVELING DOOR

List of tools to be provided by the user	
	plier

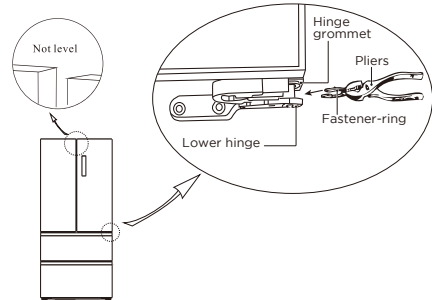

- Raise the lower door up to the level of the higher door.
- Insert the supplied fastener-ring by using plier in the gap between the hinge-grommet and the lower hinge. The number of fasten-rings you will need to insert depends on the gap.

The picture above is only for reference. The actual configuration will depend on the physical product or statement by the distributor

3. MAINTENANCE OF REFRIGERATOR

3.1 OVERALL CLEANING

- Dust behind the refrigerator and on the floor must be cleaned to improve the cooling effect and energy saving.
- Check the door gasket regularly to make sure there is no debris. Clean the door gasket with a soft cloth dampened with soapy water or diluted detergent.
- The interior of the refrigerator should be cleaned regularly to avoid odors.
- Please turn off the power before cleaning the interior, remove all foods, drinks ,shelves, drawers, etc.
- Use a soft cloth or sponge to clean the inside of the refrigerator, with two tablespoons of baking soda and a quart of warm water. Then rinse with water and wipe clean. After cleaning, open the door and let it dry naturally before turning on the power.
- For areas that are difficult to clean inside the refrigerator (such as narrow places, gaps or corners), we recommend to wipe them regularly with a soft rag, soft brush, etc. and when necessary, with some tools (such as thin sticks) to ensure no contaminants or bacterial accumulation in these areas.
- Do not use soap, detergent, scrub powder, spray cleaner, etc., as these may cause odors inside the refrigerator or contaminat food.
- Clean the door tray, shelves and drawers with a soft cloth dampened with soapy water or diluted detergent. Dry with a soft cloth or dry naturally.
- Wipe the outer surface of the refrigerator with a soft cloth dampened with soapy water, detergent, etc., and then wipe dry.
- Do not use hard brushes, scouring pads, wire brushes, abrasives (such as toothpaste), organic solvents (such as alcohol, acetone, banana oil, etc.), boiling water, acid or alkaline items, which may damage the fridge surface and interior. Boiling water and organic solvents such as benzene may deform or damage plastic parts..
- Do not rinse directly with water or other liquids during cleaning to avoid short circuit or affect electrical insulation after immersion.



Please unplug the refrigerator for frost and cleaning.

3.2 DEFROSTING

- The refrigerator is made based on the air-cooling principle and thus has automatic defrosting function. Frost formed due to change of season or temperature may also be manually removed by disconnection of the appliance from power supply or by wiping with a dry towel.

3.3 OUT OF OPERATION

- Power failure: In case of power failure, even if it is in summer, foods inside the appliance can be kept for several hours; during the power failure, the times of door opening shall be reduced, and no more fresh food shall be put into the appliance.
- Long-time nonuse: The appliance shall be unplugged and then cleaned; then the doors are left open to prevent odor.
- Moving: Before the refrigerator is moved, take all objects inside out, fix the glass partitions, vegetable holder, freezing chamber drawers and etc. with tape, and tighten the leveling feet; close the doors and seal them with tape. During moving, the appliance shall not be laid upside down or horizontally, or be vibrated; the inclination during movement shall be no more than 45°.

IMPORTANT:

The appliance shall run continuously once it is started. Generally, the operation of the appliance shall not be interrupted; otherwise the service life may be impaired

3.4 CLEANING OF DOOR TRAY

- According to the direction arrow in the figure below, use both hands to squeeze the tray, and push it upward, then you can take it out.
- After washing the tray having been taken out, you can adjust its installing height in accordance with your requirement.

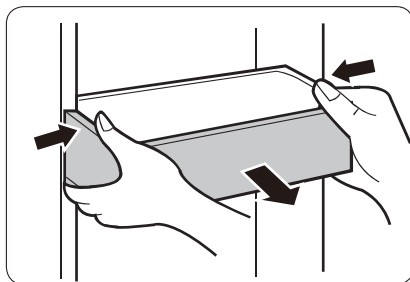

3.5 CLEANING OF SHELF

- Please adjust the cantilever rack by following the arrows as shown in the diagram.
- Raise it upward first and then take it out by tilting it upward.
- During installation, put the upper end of the fixed leg into one of the upper slots on the supporting iron first and then put the lower end of the fixed leg into the third slot on the lower part of the supporting iron.

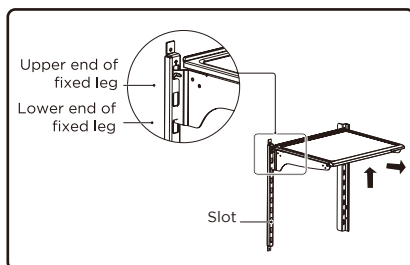

3.6 INSTALLING THE WATER LINE

- Installing the Water Line

Water line installation kits are available as an additional accessory from your dealer or at a local hardware store.

- Connecting To The Water Supply Line

a) First, shut off the main water supply line and turn the ice-maker off;

b) Locate the nearest cold water supply valve;

c) After connecting the water supply to the water valve, turn your main water supply back on and flush several gallons of water to clear the water supply line.

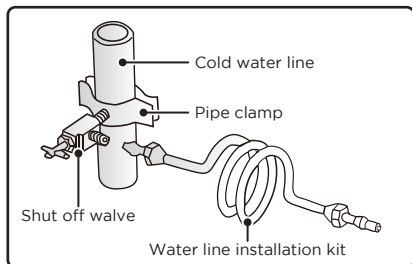

The minimum inlet water pressure: 147KPa
The maximum inlet water pressure: 834KPa

- Connecting the Water Line to The Refrigerator.

There are several items that you need to purchase to complete this connection.

You will find these items sold as a kit at your local hardware store.

a) First, water tubes (supplied) insert into corresponding hole of water connector (supplied);

b) Second, water line installation kit (not included) inserts into another hole of water connector (supplied);

c) Turn water valve on and check for any leakage.

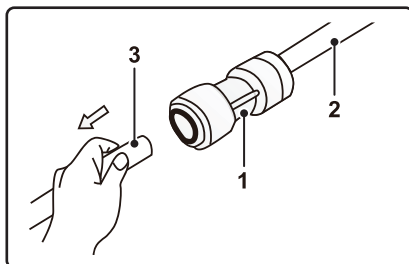

- Connecting the Water Line to A Drinkable water Source

If your water line is NOT drinkable, please add an external water filter.

If you must repair or disassemble the water line, cut off the plastic tubing to make sure you get a snug, leak-free connection.

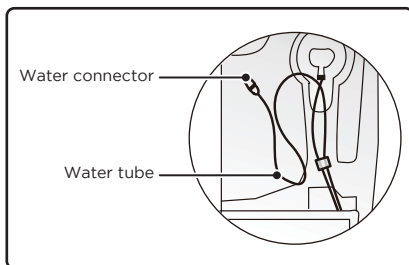

3.7 CLEANING OF FREEZER LOWER DRAWER

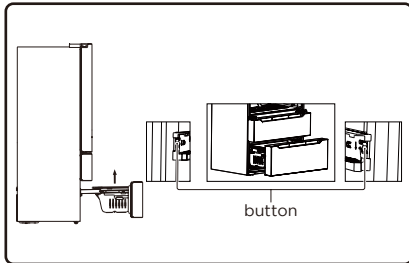

- Pull out the lower freezer drawer to the proper position.
- As shown in the Fig., press the buttons in both slots respectively(must press both sides at the same time), pull out the freezer drawer until it stops.
- Take out the lower drawer as directed by the arrows.
- After cleaning, put back the drawer to original position, then close the lower drawer, the button will lock the drawer automatically.

NOTE

Don't remove the lower freezer drawer if not necessary.

4. TROUBLE SHOOTING

The following simple issues can be handled by the user. Please call the after-sale service department if the issues are not solved.

Failed operation	<p>Check whether the appliance is connected to power or whether the plug is in well contact</p> <p>Check whether the voltage is too low</p> <p>Check whether there is a power failure or partial circuits have tripped</p>
Odor	<p>Odorous foods shall be tightly wrapped</p> <p>Check whether there is any rotten food</p> <p>Clean the inside of the refrigerator</p>
Long-time operation of the compressor	<p>Long operation of the refrigerator is normal in summer when the ambient temperature is high It is not suggestible having too much food in the appliance at the same time</p> <p>Food shall get cool before being put into the appliance</p> <p>The doors are opened too frequently</p>
Light fails to get lit	<p>Check whether the refrigerator is connected to power supply and whether the illuminating light is damaged</p> <p>Have the light replaced by a specialist</p>
Door can not be properly closed	<p>The door is stuck by food packages Too much food is placed</p> <p>The refrigerator is tilted.</p>
Loud noises	<p>Check whether the floor is level and whether the refrigerator is placed stably</p> <p>Check whether accessories are placed at proper locations</p>
Door seal fails to be tight	<p>Remove foreign matters on the door seal</p> <p>Heat the door seal and then cool it for restoration (or blow it with an electrical drier or use a hot towel for heating)</p>
Water pan overflows	<p>There is too much food in the chamber or food stored contains too much water,resulting in heavy defrosting</p> <p>The doors are not closed properly, resulting in frosting due to entry of air and increased water due to defrosting</p>
Hot housing	<p>Heat dissipation of the built-in condenser via the housing, which is normal</p> <p>When housing becomes hot due to high ambient temperature, storage of too much food or shutdown of the compressor is shut down, provide sound ventilation to facilitate heat dissipation</p>
Surface condensation	<p>Condensation on the exterior surface and door seals of the refrigerator is normal when the ambient humidity is too high. Just wipe the condensate with a clean towel.</p>
Abnormal noise	<p>Buzz: The compressor may produce buzzes during operation, and the buzzes are loud particularly upon start or stop. This is normal.</p> <p>Creak: Refrigerant flowing inside of the appliance may produce creak, which is normal.</p>

Criterion® Refrigerator Warranty

Your product is protected by this warranty:

Warranty service must be obtained from Midea Consumer Services or an authorized Midea servicer.

Warranty

- One year full warranty from original purchase date, includes compressor, parts and labor only.

Midea, through its authorized servicers will:

- Pay all costs for repairing or replacing parts of this appliance which prove to be defective in materials or workmanship.

Midea is not responsible for:

- Diagnostics, removal, transportation and reinstallation cost required because of service.
- Costs of service calls that are a result of items listed under **NORMAL RESPONSIBILITIES OF THE CONSUMER****

Midea replacement parts shall be used and will be warranted only for the period remaining on the original warranty.

NORMAL RESPONSIBILITIES OF THE CONSUMER**

This warranty applies only to products in ordinary household use, and the consumer is responsible for the items listed below:

1. Proper use of the appliance in accordance with instructions provided with the product.
2. Routine maintenance and cleaning necessary to keep the good working condition.
3. Proper installation by an authorized service professional in accordance with instructions provided with the appliance and in accordance with all local plumbing, electrical and / or gas codes.
4. Proper connection to a grounded power supply of sufficient voltage, replacement of blown fuses, repair of loosened connections or defects in house wiring.
5. Expenses for making the appliance accessible for servicing.
6. Damages to finish after installation.

EXCLUSIONS

This warranty does not cover the following:

1. Failure caused by damage to the unit while in your possession (other than damage caused by defect or malfunction), by its improper installation, or by unreasonable use of the product, including without limitation, failure to provide reasonable and necessary maintenance or to follow the written Installation and Operating Instructions.
2. Products purchased "as-is" or refurbished are not covered by this warranty.
3. Food loss caused by refrigerator or freezer failure.
4. Service calls to repair or replace consumables such as water filters, light bulbs air filters etc., or handles, knobs and other cosmetic parts.
5. Product that has been transferred from its original owner.
6. Interior or exterior rust on the unit.
7. Damages caused by services performed by persons other than authorized Midea servicers; use of parts other than Midea replacement parts; obtained from persons other than such Midea customer service; or external causes such as abuse, misuse, inadequate power supply or acts of God.
8. Service calls resulting from improper installation of your product.
9. Service calls to instruct you on the use of your product.
10. Surcharges including, but not limited to, any after hour, weekend, or holiday service calls, tolls, ferry trip charges, or mileage expense for service calls to remote areas, including the state of Alaska.
11. If the unit is put to commercial, business, rental, or other use or application other than for consumer use, we make no warranties, express or implied, including but not limited to, any implied warranty of merchantability or fitness for particular use or purpose.
12. Product that has been removed outside the USA or Canada.
13. Products without original serial numbers or products that have serial numbers which have been altered or cannot be readily determined.

Note: Some states do not allow the exclusion or limitation of incidental or consequential damages. So this limitation or exclusion may not apply to you.

IF YOU NEED SERVICE

Keep your bill of sale, delivery slip, and other appropriate payment record.

The date on the bill established the warranty period should service be required.

If service is performed, it is your best interest to obtain and keep all receipts.

This written warranty gives you specific legal rights. You may also have other rights that vary from state to state.

Service under this warranty must be obtained by following these steps, in order:

1. Contact Midea Consumer Services or an authorized Midea servicer at 1-866-646-4332
2. If there is a question as to where to obtain service, contact our consumer relations Department.

Criterion®

Tarjeta de Registracion de Producto

Es sencillo! Complete y envíe su Tarjeta de Registracion de Producto hoy!

Nombre

Dirección

Ciudad Estado Código postal

Teléfono (Opcional) / -

Dirección de E-mail (Opcional)

Donde Comprado

Numero de Modelo
220250d418

Numero de Serie
REV 11/04

Mes Dia Año
Fecha de la compra

Porfavor devuelve su Tarjeta de Registracion de Producto hoy!

Criterion®

Product Registration Card

It's simple! Complete and mail your Product Registration Card today!

Name

Address

City State Zip

Phone (Optional) / -

E-mail Address (Optional)

Where Purchased

Model Number
220250d418

Serial Number
REV 11/04

Month Day Year
Date of Purchase

Please return your Product Registration Card today!

1-866-646-4332

Su producto está protegido por esta garantía:
Su producto está garantizado por Midea. Cualquier obligación de proporcionar servicio o repuestos establecida en esta garantía deberá ser cumplida por los Servicios al consumidor de Midea o por un representante autorizado de Midea.
Para comunicarse con un Representante de Servicio al Cliente, tenga la bondad de llamar por teléfono sin cargo alguno a Midea, al número:

Garantía

1-866-646-4332

Your product is protected by this warranty:
Your appliance is warranted by Midea. Any obligations for services and parts under this warranty must be performed by Midea Consumer Services or an authorized Midea service
To contact a Customer Service Representative, Call Midea TOLL FREE

Product Warranty

Product Warranty Card
Tarjeta de Garantía de Producto



Criterion®



Postage
Required.
Post Office will
not deliver
without proper
postage.

PLACE
STAMP
HERE

Criterion®



Product Support
Midea America Corp.
759 Bloomfield Ave. # 386
West Caldwell, NJ 07006

Criterion®