

# Criterion™

# User's Manual

## Chest Freezer

13.7 cu. ft. (4535421) • 18.3 cu. ft. (4535422)

**BEFORE USING YOUR PRODUCT:** Please read this manual carefully & follow all safety rules & operating instructions. Keep this manual for future reference.

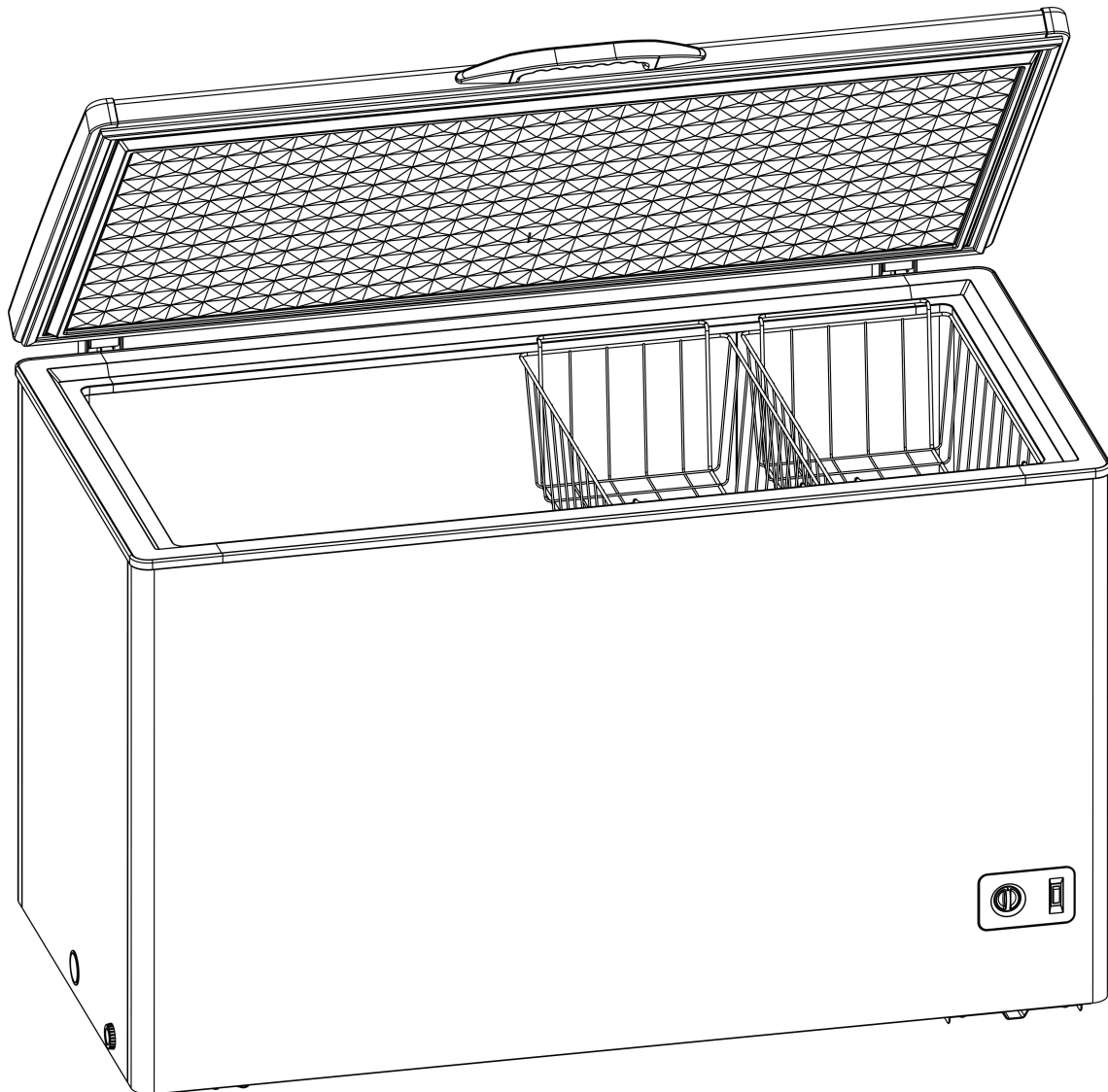

# GENERAL SAFETY RULES



**WARNING:** Read all of the instructions before using this appliance. When using this appliance, always exercise basic safety precautions, including the following:

**NOTE:** If the freezer has been placed in a horizontal or tilted position for any period of time wait 24 hours before plugging the unit in.

1. Use this appliance only for its intended purpose as described in this use and care guide.
2. This freezer must be properly installed in accordance with the installation instructions before it is used. See grounding instructions in the installation section.
3. Use 3 prong grounded plug provided on power cord.
4. Never unplug your freezer by pulling on the power cord. Always grasp the plug firmly and pull straight out from the outlet.
5. Repair or replace immediately, all electric service cords that have become frayed or otherwise damaged. Do not use a cord that shows cracks or abrasion damage along its length, the plug or the connector end.
6. Unplug your freezer before cleaning or before making any repairs.
7. Do not use any electrical device or any sharp instrument in defrosting your freezer.
8. If your old freezer is not being used, we recommend that you remove the doors. This will reduce the possibility of danger to children.



**WARNING:** After your freezer is in operation, do not touch the cold surfaces in the freezer compartment, particularly when hands are damp or wet. Skin may adhere to these extremely cold surfaces.

9. Do not refreeze foods, which have been thawed completely. The United States Department of Agriculture recommends "...You may safely refreeze frozen foods that have thawed if they still contain ice crystals or if they are still cold-below 40°F".

"...Thawed ground meats, poultry, or fish that have any off-odor or off-color should not be refrozen and should not be eaten. Thawed ice cream should be discarded. If the odor or color of any food is poor or questionable, discard it. The food may be dangerous to eat."

"...Even partial thawing and re-freezing reduce the consumption quality of foods, particularly fruits, vegetables, and prepared foods. The consumption quality of red meats is affected less than that of many other foods. Use refrozen foods as soon as possible, to save as much of its eating quality as you can."

10. Do not clean with flammable fluids. Do not store flammable liquids in freezer.
11. This freezer should not be recessed or built-in an enclosed cabinet. It is designed for freestanding installation only.
12. Do not operate your freezer in the presence of explosive fumes.

## **SAVE THESE INSTRUCTIONS**



**DANGER**

**Risk of child entrapment. Before you throw away your old refrigerator or freezer, take off the doors.**

**Staple your receipt to your manual.  
You will need it to obtain warranty service.**

# Parts And Features

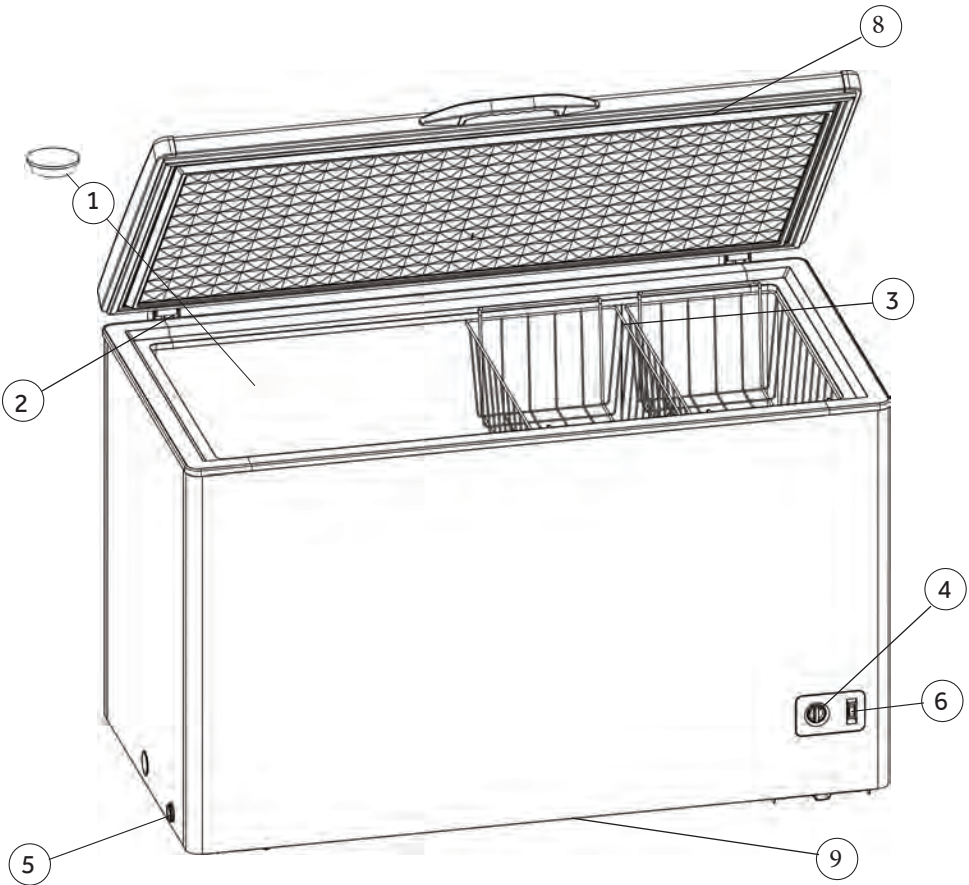

1. Interior Drain Plug
2. Lid Hinge
3. Vinyl Coated Wire Baskets
4. Temperature Control:  
OFF, Temperature Settings
5. Exterior Drain Plug
6. Power On Indicator
7. Power Cord
8. Lid Gasket
9. 2 Locking & 2 non-Locking casters

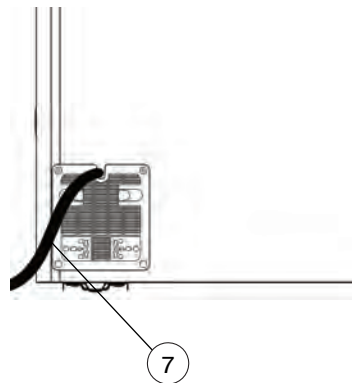

# Installing Your Freezer

## Unpacking Your Freezer

- 1 Place the freezer on a floor strong enough to support it fully loaded.
- 2 Remove all packaging material. This includes the foam base and all adhesive tape holding the freezer accessories inside and outside.
- 3 Inspect and remove any remains of packing, tape or printed materials before powering on the freezer.

## Installing Your Freezer

- 1 Install on a level surface.
- 2 Allow 4 hours after installation before connecting to power source.
- 3 Allow unit to operate for 6–8 hours before placing food inside.
- 4 Clean interior with lukewarm water and mild detergent using sponge or soft cloth. Be sure interior is dry before using.

## Proper Air Circulation

To assure your freezer works at the maximum efficiency it was designed for, install in a location where there is proper air circulation, plumbing and electrical connections.

The following are recommended clearances around the freezer:

Sides	4" (102mm)
Back	4" (102mm)
Top	Do not block

## Adjusting Your Freezer

- 1 Your freezer is designed for freestanding installation only. It should not be recessed or built-in.
- 1 When moving the freezer, never tilt it more than a 45-degree angle. This could damage the compressor and the sealed system.
- 2 If the freezer is tilted let it stand in an upright position for at least 24 hours prior to plugging in the unit. This is to allow the refrigerant to settle.



## **WARNING:** ELECTRICAL REQUIREMENT - SHOCK HAZARD

### **Electrical Requirement**

1. Make sure there is a suitable power Outlet (115 volts, 15 amps outlet) with proper grounding to power the freezer.
2. Avoid the use of three plug adapters or cutting off the third grounding in order to accommodate a two plug outlet. This is a dangerous practice since it provides no effective grounding for the freezer and may result in shock hazard.
3. Use a surge protector if possible.



### **Use of Extension Cord**

1. Avoid the use of an extension cord because of potential safety hazards under certain conditions. If it is necessary to use an extension cord, use only a 3-wire extension cord that has a 3-blade grounding plug and a 3-slot outlet that will accept the plug. The marked rating of the extension cord must be equal to or greater than the electrical rating of the appliance.
2. **DO NOT USE EXTENSION CORD LONGER THAN 12 FT.**

### **Install Limitations**

1. Do not install your freezer in any location not properly insulated or heated. Your freezer was not designed to operate in temperature environments below 23° Fahrenheit.
2. Select a suitable location for the freezer on a hard even surface away from direct sunlight or heat source e.g. radiators, baseboard heaters, cooking appliances etc. Any floor unevenness should be corrected.

# Freezer Features and Use

## Operating Your Freezer

- Once the freezer is in its proper place, plug it in an electrical outlet having 115 volts and 15 amps.
- Set the temperature, on the temperature control knob. “MIN” is cold and “MAX” is coldest. Initially set the temperature on “4”. Place food inside the freezer. After using the freezer for 24 hours set the freezer to your desired setting.
- In case you unplug your freezer or experience an electrical outage, allow 5 minutes before plugging it back in.

## General Features

### Adjustable temperature dial: (see fig. # 1)

Your freezer will automatically maintain the temperature level you select. The temperature control dial has 7 settings plus OFF. “MIN” is cold “MAX” is coldest. Set the dial to “4” and allow 24 hours to pass before adjusting the temperature to your needs.

### For faster freezing capability:

The first time you turn the unit on, turn the temperature control dial to “MAX” and run for at least 2 hours, then turn dial to “4”.

**(Note: If the freezer has been placed in a horizontal or tilted position for any period of time wait 24 hours before plugging the unit in.)**

fig. # 1

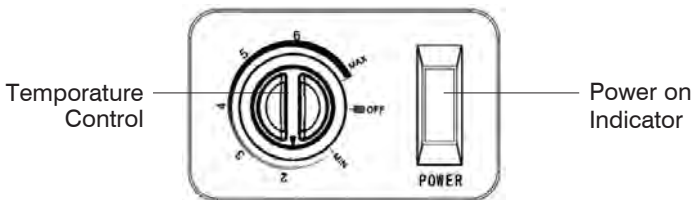

## Normal Operating Sounds You May Hear

- Boiling water, gurgling sounds or slight vibrations that are the result of the refrigerant circulating through the cooling coils.
- The thermostat control will click when it cycles on and off.

## Food Storage Basket

- Your freezer has 2 baskets. Removable basket allows you to store food more accessibly or you can remove it if not needed.

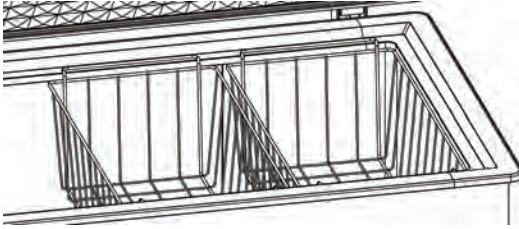

## Defrosting and Draining

- For most efficient operation and minimum energy consumption, defrost whenever the frost becomes 1/4" thick. Never use a sharp or metallic instrument to remove the frost, as it may damage the cooling coils. (A punctured coil will void the warranty). Do not use boiling water as it may damage the unit. It is advisable to let ice and frost melt naturally.
- Remove frozen food from the freezer and place it in a cooler to protect the food.
- Unplug the unit. Defrosting usually takes a few hours. To defrost faster keep the freezer door open.
- For draining, place a tray beneath the outer drain plug. Unscrew and remove drain plug. This will let the water flow out in the tray. When done, screw on the drain plug in place.  
Note: monitor the container under the drain to avoid overflow.
- When draining is complete, wipe the interior of the freezer with a soft cloth. Plug in power cord back into the electrical outlet.
- Reset the temperature control to the desired setting.
- Return the food into the freezer.



# Food Storage Information

## Frozen Food:

- Wipe containers before storing to avoid needless spills.
- Hot food should be allowed to cool before storing in the freezer. This will prevent unnecessary energy use.
- When storing meats, keep in the original packaging or rewrap as necessary.
- Proper freezer storage requires correct packaging. All foods must be in packages, which do not allow the flow of air or moisture in, or out. Improper storage will result in odor and taste transfer and will result in the drying out of the improperly packaged food.
- Follow package or container instructions for proper storage.
- Packaging Recommendations:
  - Plastic containers with air tight lids
  - Heavy duty aluminum foil
  - Plastic wrap made from saran film
  - Self-sealing plastic bags
- Do not refreeze defrosted/thawed foods.
- It is recommended that the freezing date be marked on the packaging.

## These are some suggestions for safe storage:

- |                                    |               |
|------------------------------------|---------------|
| • TV Dinners                       | 3 - 4 Months  |
| • Fresh Shrimp, Scallops, Crawfish | 3 - 6 Months  |
| • Hamburgers, Stew Meats           | 3 - 4 Months  |
| • Ground Turkey, veal, pork        | 4 - 6 Months  |
| • Chops                            | 4 - 6 Months  |
| • Steaks                           | 6 - 12 Months |
| • Chicken or Turkey, whole         | 1 - Year      |

For detailed storage chart visit FDA website: [www.FDA.gov](http://www.FDA.gov)

# Proper Freezer Care and Cleaning

## Cleaning and Maintenance



**WARNING:** To avoid electric shock always unplug your freezer before cleaning. Ignoring this warning may result in death or injury.



**CAUTION:** Before using cleaning products, always read and follow manufacturer's instructions and warnings to avoid personal injury or product damage.

## General:

- Prepare a cleaning solution of 3-4 tablespoons of baking soda mixed with warm water. Use sponge or soft cloth, dampened with the cleaning solution, to wipe down your freezer.
- Rinse with clean warm water and dry with a soft cloth.
- Do not use harsh chemicals, abrasives, ammonia, chlorine bleach, concentrated detergents, solvents or metal scouring pads. SOME of these chemicals may dissolve, damage and/or discolor your freezer.

## Door Gaskets:

- Clean door gaskets every three months according to general instructions. Gaskets must be kept clean and pliable to assure a proper seal.
- Petroleum jelly applied lightly on the hinge side of gaskets will keep the gasket pliable and assure a good seal.

## Power Interruptions

- Occasionally there may be power interruptions due to thunderstorms or other causes. Remove the power cord from AC outlet when a power outage occurs. When power has been restored, replug power cord to AC outlet. If outage is for a prolonged period, inspect and discard spoiled or thawed food in freezer. Clean freezer before reusing.

## Vacation and Moving Care

- For long vacations or absences, empty food from freezer, unplug the unit and clean the door gaskets according to “General cleaning” section. Prop doors open, so air can circulate inside. When moving always move the freezer vertically. Do not move with the unit lying down. Possible damage to the sealed system could occur.



**WARNING:** IF OUTAGE IS FOR A PROLONGED PERIOD, INSPECT AND DISCARD SPOILED OR THAWED FOOD IN FREEZER. CLEAN FREEZER BEFORE REUSING.

# Troubleshooting

## Freezer Does Not Operate:

- Check if freezer is plugged in.
- Check if there is power at the AC outlet, by checking the circuit breaker.
- Wait for 30-40 minutes to see whether freezer will start. Compressor cycle must be complete to operate.
- Check Temperature Control.

## Food temperature appears too warm:

- Frequent door openings.
- Check door to be sure it is closed properly.
- Allow time for recently added warm food to reach freezer temperature.
- Check gaskets for proper seal.
- Adjust temperature control to colder setting.

## Food temperature is too cold:

- If temperature control setting is too cold, adjust to a warmer setting and allow several hours for temperature to adjust.
- Ice build-up on interior walls

## Too much frost build-up inside unit:

- Make sure temperature control is not set to “MAX” setting for extended period of time.

## Vibration:

- Make sure the unit is level.
- Check to be sure the unit is not touching the wall.
- Double check whether the unit has been properly installed.

## **Compressor runs too frequently:**

- This may be normal to maintain constant temperature during high temperature and humid days.
- Doors may have been opened frequently or for an extended period of time.
- Check gasket for proper seal.
- Check to see if doors are completely closed.
- Check freezer compartment for blockage from frozen food packages, containers, etc.

## **Freezer has an odor:**

- Interior needs cleaning.
- Foods improperly wrapped or sealed are giving off odors.

# **One Year Limited Warranty**

Manufacturer provides a limited warranty for each new chest freezer to be free from defects in material and workmanship for a period of one year from the date of purchase. Manufacturer agrees to remedy any such defective inside accessory components such as door panels, door shelves, racks, handles, casters, bins and drawers or to furnish a new unit if the unit proves to have failed, at the company's option, for one year from your original date of purchase. Buyer must register unit at [PlasticDevelopmentGroup.com/applianceregistration](http://PlasticDevelopmentGroup.com/applianceregistration). In the event the unit requires replacement or refund under the terms of this limited warranty, the Buyer is responsible for all transportation expenses to return the unit prior to receiving a replacement unit or refund. A copy of the dated sales receipt/invoice is required to receive benefits of this limited warranty.

See following page for full **1 Year Limited Warranty**

# One Year Limited Warranty

This limited warranty covers appliances in use within the continental United States, Alaska, and Hawaii, and Puerto Rico. This limited warranty does not cover the following:

1. Products with original serial numbers that have been removed, altered or cannot be readily determined.
2. Products that have been transferred from its original owner to another party or removed outside the USA.
3. Rust on the interior or exterior of the unit.
4. Damages due to shipping damage or improper installation.
5. Damages due to misuse or abuse.
6. Service calls, repairs, and labor expenses for any purpose.
7. Content losses and food spoilage due to failure of the unit.
8. Punctures to the evaporation system due to improper defrosting of the unit.
9. Replacement or resetting of house fuses or circuit breakers.
10. Failure or defects of this product if used for other purposes than its intended purpose or used other than in accordance with the provided instructions.
11. Disposal costs for failed unit not returned to Manufacturer.
12. Any delivery/installation costs incurred as the result of a unit that fails to perform as specified.
13. Expenses for travel and transportation for product if you are exchanging or returning the unit.
14. Expenses related to the removal and re-installation of your unit or for making the unit accessible, such as removal of trim, cupboards, shelves, etc. or if not installed in accordance with the provided installation instructions.
15. Damages to the finish of the unit or home incurred during installation, including but not limited to floors, cabinets, walls, etc.
16. Damages caused by external causes such as abuse, misuse, inadequate power supply, accidents, fires, or acts of God.
17. Refunds for returned products are limited to the price paid for the unit per the sales receipt.

**Disclaimer of Implied Warranties, Limitation of Remedies and Exclusions:**

EXCEPT FOR THE EXPRESS WARRANTIES SET FORTH HEREIN, MANUFACTURER MAKES NO WARRANTY WHATSOEVER (OR THE SHORTEST PERIOD ALLOWED BY LAW) REGARDING THE GOODS, INCLUDING ANY (1) WARRANTY OF MERCHANTABILITY; (2) WARRANTY OF FITNESS FOR A PARTICULAR PURPOSE; (3) WARRANTY OF TITLE; OR (4) WARRANTY AGAINST INFRINGEMENT OF INTELLECTUAL PROPERTY RIGHTS OF A THIRD PARTY; WHETHER ARISING BY LAW, COURSE OF DEALING, COURSE OF PERFORMANCE, USAGE OF TRADE, OR OTHERWISE. BUYER ACKNOWLEDGES THAT IT HAS NOT RELIED ON ANY REPRESENTATION OR WARRANTY MADE BY MANUFACTURER, OR ANY OTHER PERSON ON MANUFACTURER'S BEHALF. REPLACEMENT OF UNIT AND LISTED PARTS IN ACCORDANCE WITH THE TERMS HEREIN, IS YOUR SOLE AND EXCLUSIVE REMEDY UNDER THIS LIMITED WARRANTY. MANUFACTURER IS NOT LIABLE FOR INCIDENTAL OR CONSEQUENTIAL DAMAGES AND NO REPRESENTATIVE OR PERSON IS AUTHORIZED TO ASSUME FOR MANUFACTURER ANY OTHER LIABILITY IN CONNECTION WITH THE SALE OF THIS PRODUCT. UNDER NO CIRCUMSTANCE IS THE CONSUMER PERMITTED TO RETURN THE UNIT TO MANUFACTURER WITHOUT THE PRIOR WRITTEN CONSENT OF MANUFACTURER.

Customer Service, (toll free: 833-953-1758) between the hours of 8:00 am and 4:00 pm CT

EMAIL: [appliances@plasticdevelopmentgroup.com](mailto:appliances@plasticdevelopmentgroup.com)

Product Registration: [plasticdevelopmentgroup.com/applianceregistration](http://plasticdevelopmentgroup.com/applianceregistration)

